

Copper Double Slipper

Hammered Exterior with Tinned Hammered Interior

Tub Dimensions: 71" L x 33" W x 32" H

Water Capacity: 105 Gallons

Tub Weight Uncrated: 170 lbs. Tub Weight Crated: 325 lbs.

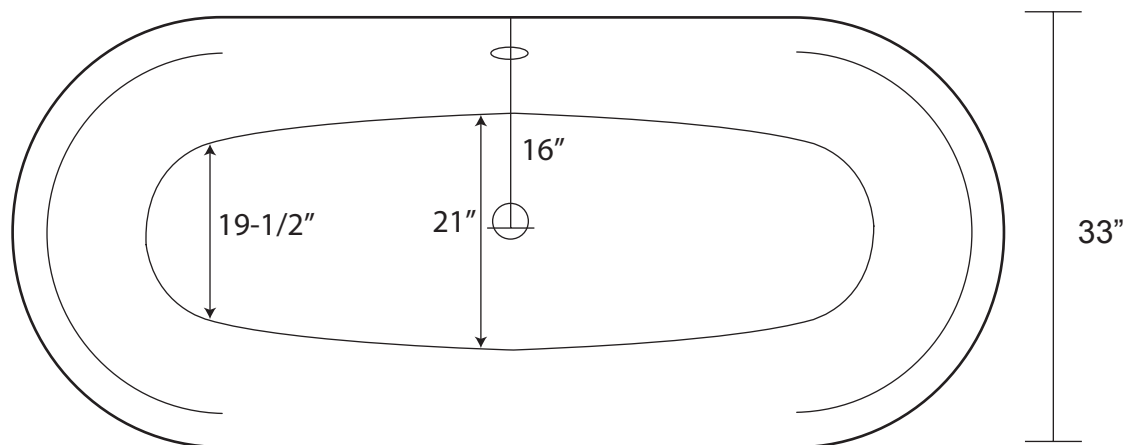
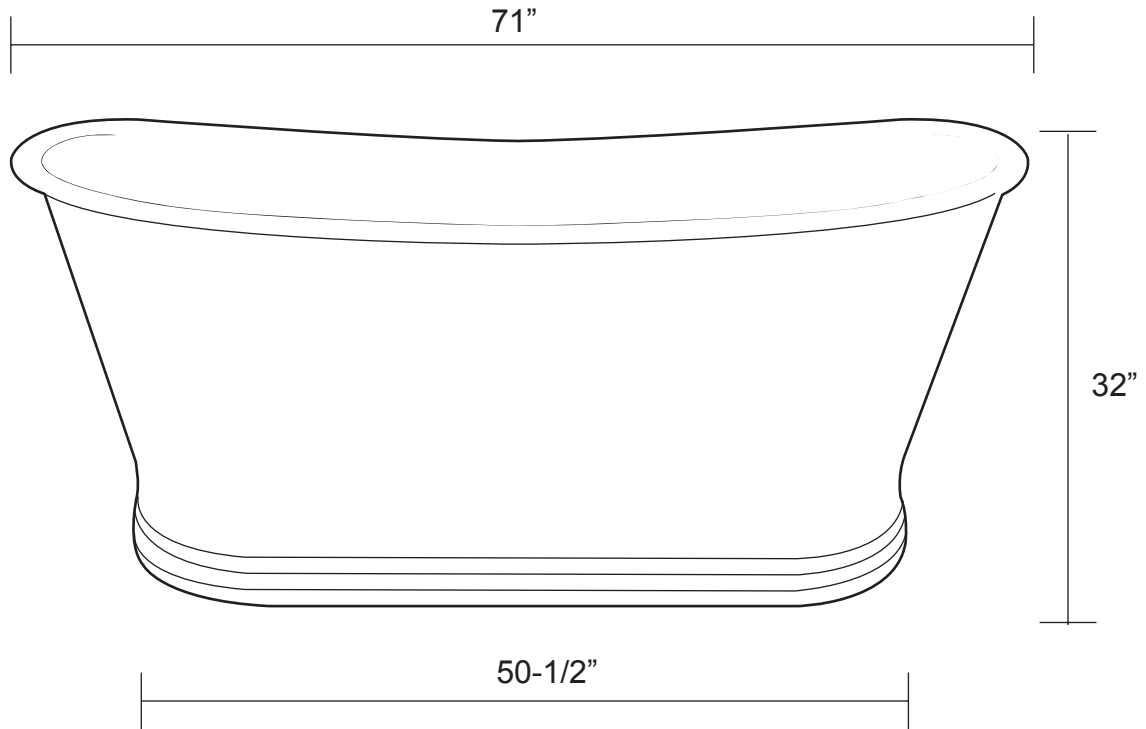

Water depth to overflow is 20" H.

Overflow hole is 1-1/2" diameter.

Tub rim is 2-5/8" wide.

All measurements are approximate. Measurements may vary +/- 1/2".