

# Copper Double Slipper

Hammered Interior and Exterior

Tub Dimensions: 71" L x 32" W x 33" H

Water Capacity: 105 Gallons

Tub Weight Crated: 345 lbs. Tub Weight Uncrated: 165 lbs.

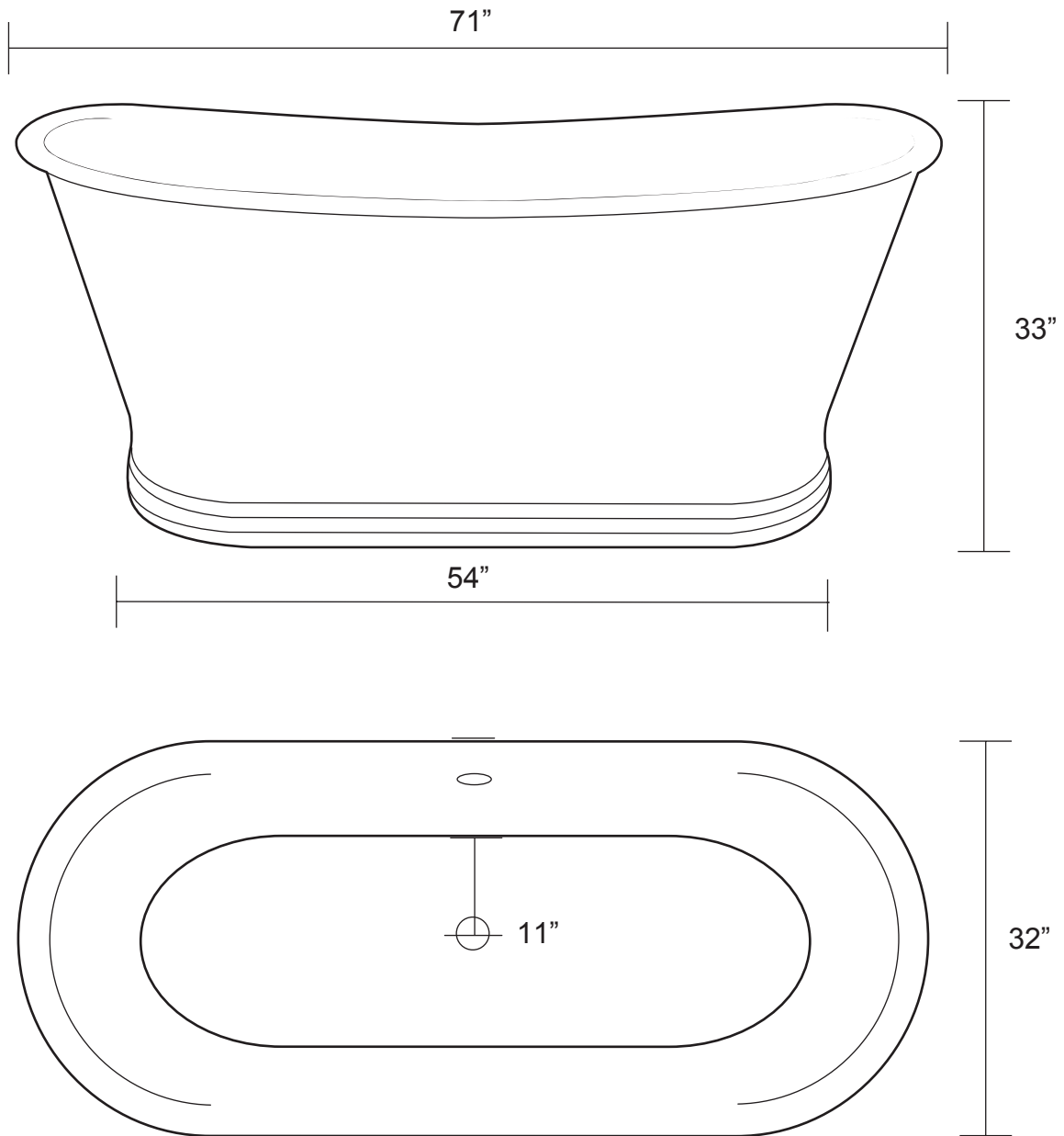

Water depth to overflow is 19".

Overflow hole is 1-1/2" diameter.

Tub rim is 2-5/8" wide.

All measurements are approximate. Measurements may vary +/- 1/2".